

To specify directions, use the coordinate system shown below where $+x$ is to the right, $+y$ is toward the top of the page, and $+z$ is out of the page.

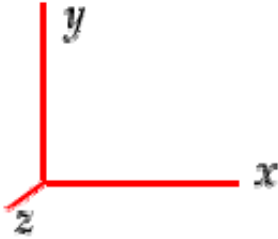

Note the following terminology for directions:

- to the right ($+x$)
- to the left ($-x$)
- upward or toward the top of the page ($+y$)
- downward or toward the top of the page ($-y$)
- out of the page ($+z$) \odot
- into the page ($-z$) \otimes

Section 1. Multiple Choice

Questions 1-3: A piece of metal has a velocity in the $+y$ direction through a region of uniform magnetic field in the $+z$ direction.

1. In what direction is the magnetic force on a mobile electron that is in the metal?
 - (a) to the right
 - (b) to the left
 - (c) up, toward the top of the page
 - (d) down, toward the bottom of the page
 - (e) None of the above because the magnetic force on a mobile electron is zero.
2. Which of the images below shows the separation of charge (if there is any) on the piece of metal due to the magnetic force on mobile electrons in the metal?

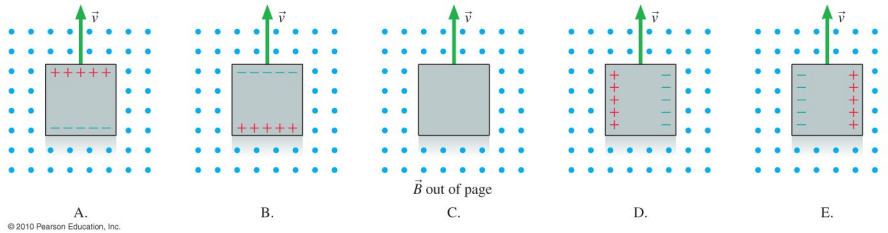

- (a) A
- (b) B
- (c) C
- (d) D
- (e) E

3. If the block of metal is 0.1 m on each side and if the magnetic field is 0.5 T, what speed is needed for the emf across the block (along the direction of charge separation) to be 1.5 V (the equivalent of a AA battery)?
- (a) 0.075 m/s
 - (b) 0.13 m/s
 - (c) 0.75 m/s
 - (d) 3.0 m/s
 - (e) 30 m/s

Questions 4–5: A coil of wire is connected to a battery. A switch can be opened or closed in order to connect and disconnect the battery.

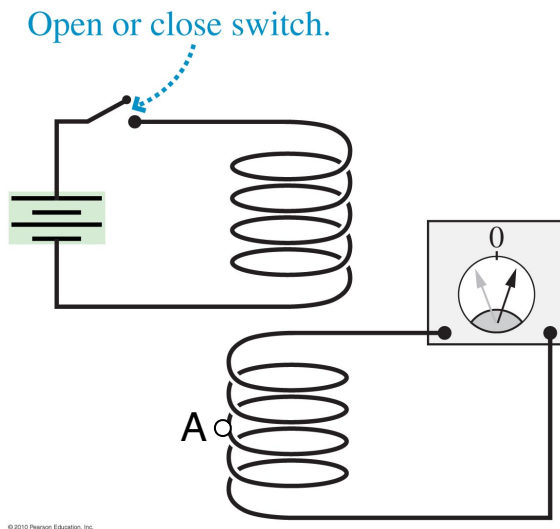

A second coil is connected to an ammeter which measures current in the coil.

4. Suppose that the switch is closed and remains closed. While the switch remains closed and the current in the top coil is constant, what is the direction of the induced current at point A in the bottom coil?
- (a) out of the page
 - (b) into the page
 - (c) Neither of the above because the induced current is zero.
5. The switch is then opened. During the brief time interval that the switch is being opened, what is the direction of the induced current at point A in the bottom coil?
- (a) out of the page
 - (b) into the page
 - (c) The induced current is zero.

Questions 6–8: A region of uniform magnetic field exists in a circle of radius 0.02 m. A square circuit of length 0.05 m is centered on this region, perpendicular to the magnetic field, as shown. Bulbs A and B are identical.

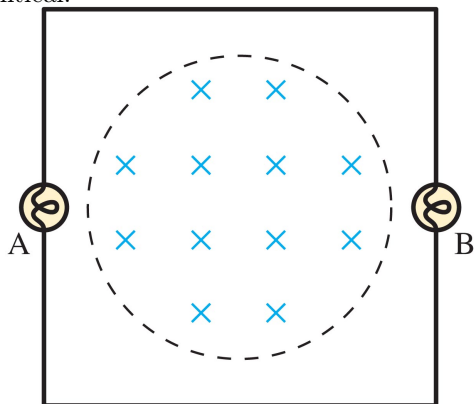

At a certain instant of time, the magnetic field has a magnitude of 2 T and is *increasing* at a rate of 0.1 T/s.

6. What is the direction of the induced current in the wire loop?
 - (a) clockwise
 - (b) counterclockwise
 - (c) None of the above since the induced current is zero.
7. If we define the area vector for the wire loop to be into the page, then the magnetic flux through the wire loop (the circuit) at this instant of time is:
 - (a) $1.26 \times 10^{-4} \text{ T} \cdot \text{m}^2$
 - (b) $2.50 \times 10^{-4} \text{ T} \cdot \text{m}^2$
 - (c) $5.00 \times 10^{-3} \text{ T} \cdot \text{m}^2$
 - (d) $2.51 \times 10^{-3} \text{ T} \cdot \text{m}^2$
 - (e) $2.00 \text{ T} \cdot \text{m}^2$
8. What is the induced emf around the circuit?
 - (a) $1.26 \times 10^{-4} \text{ V}$
 - (b) $2.50 \times 10^{-4} \text{ V}$
 - (c) $5.00 \times 10^{-3} \text{ V}$
 - (d) $2.51 \times 10^{-3} \text{ V}$
 - (e) 0.1 V

9. A rectangular wire loop is moving toward a long, current-carrying wire. In what direction does the induced current flow in the rectangular loop?

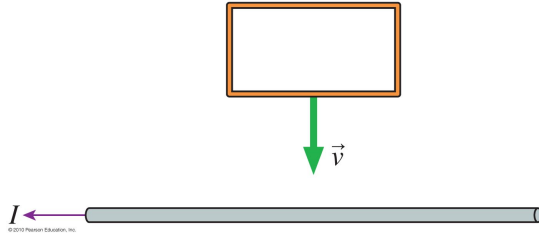

- (a) clockwise
 (b) counterclockwise
 (c) Neither because the induced current is zero.

Questions 10–14: A positively charged particle is at rest at the instant shown below. A short time interval before this, the particle was moving with a constant velocity. During the brief time interval that it slowed down and stopped, an electromagnetic pulse was created.

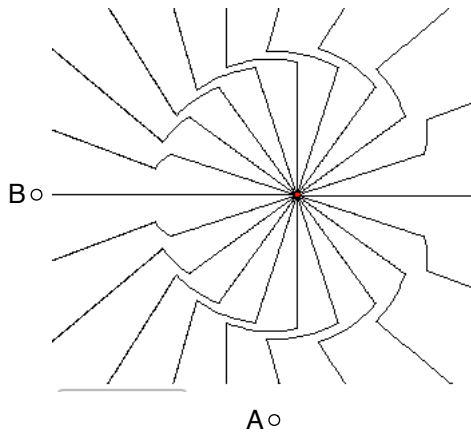

10. What is the direction of the radiative electric field at location A when the electromagnetic pulse passes location A?
- (a) $+z$
 (b) $-z$
 (c) $+x$
 (d) $-x$
 (e) $-y$
11. The electromagnetic pulse is traveling radially outward from the charged particle. What is the direction of the velocity of the electromagnetic pulse when it passes location A?
- (a) $+z$
 (b) $-z$
 (c) $+x$
 (d) $-x$
 (e) $-y$

12. What is the direction of the radiative magnetic field at location A when the electromagnetic pulse passes location A?
- (a) $+z$
 - (b) $-z$
 - (c) $+x$
 - (d) $-x$
 - (e) $-y$
13. During a time interval that your cell phone is emitting electromagnetic radiation (in radio frequencies), the electrons in the antenna of the phone are
- (a) at rest and remaining at rest
 - (b) moving with a constant velocity
 - (c) accelerating
14. If point A is 2 m from the particle, how long does it take for the pulse to reach point A?
- (a) 6.7 ns
 - (b) 1.5 ns
 - (c) 3.0 ns
 - (d) 2.0 ns
 - (e) 3.3 ns
15. The energy levels for a certain quantum system are 1.0 eV, 4.0 eV, and 6.0 eV. Sketch an energy diagram. What are the energies of the photons that can possibly be emitted by the system?
- (a) 1.0 eV, 4.0 eV, and 6.0 eV
 - (b) 5.0 eV, 7.0 eV, and 10.0 eV
 - (c) 2.0 eV and 3.0 eV
 - (d) 2.0 eV, 3.0 eV, and 5.0 eV
 - (e) 4.0 eV and 6.0 eV
16. It is possible for a small current to flow through the filament of the bulb yet the bulb does not give off visible light. In this case, its peak wavelength is in the
- (a) UV region
 - (b) X-ray region
 - (c) violet region
 - (d) red region
 - (e) IR region
17. Suppose that you measure the spectrum of a glowing filament of a certain light bulb. You find that the wavelength of its peak is 610 nm. What is the temperature of the filament?
- (a) 1770 K
 - (b) 2100 K
 - (c) 4750 K
 - (d) 6100 K
 - (e) 5230 K

18. If you increase the temperature of the filament of the bulb in the previous question (by increasing the current through it), the wavelength of the peak will be
- (a) the same as before.
 - (b) longer than before.
 - (c) shorter than before.
19. Suppose that the wavelength of the peak of the spectrum from a blackbody, such as a star or filament for example, is 530 nm. This object will appear
- (a) green
 - (b) orange
 - (c) blue
 - (d) white
 - (e) none of the above
20. What is the wavelength of 25 keV x-ray photons used in medical imaging?
- (a) 12 pm
 - (b) 25 pm
 - (c) 31 pm
 - (d) 50 pm
 - (e) 83 pm
21. A laser emits 1×10^{16} photons per second. The photons have a wavelength of 650 nm. What is the power of the laser in watts?
- (a) 4.6×10^{-3} W
 - (b) 1.9 W
 - (c) 1.6×10^{-3} W
 - (d) 1.0 W
 - (e) 3.1×10^{-3} W
22. A blue laser and a green laser both emit light of power 2 mW. Which laser emits more photons per second?
- (a) blue laser
 - (b) green laser
 - (c) Neither; they emit the same number of photons per second.

Questions 23–26 are related to a hydrogen atom.

23. A hydrogen atom transitions from orbit $n = 3$ to orbit $n = 5$. Did it emit or absorb a photon?
- (a) It absorbed a photon.
 - (b) It emitted a photon.
 - (c) It could have either absorbed a photon or emitted a photon.
24. For the previous question, what energy photon is emitted or absorbed?
- (a) 3.40 eV
 - (b) 1.51 eV
 - (c) 2.48 eV
 - (d) 0.97 eV
 - (e) 0.54 eV

25. As the energy state n increases, the *difference* between the energies of consecutive energy levels
- (a) decreases.
 - (b) increases.
 - (c) stays the same.
26. How many photons in the visible region of the spectrum does a hydrogen atom absorb or emit?
- (a) two
 - (b) three
 - (c) four
 - (d) five
 - (e) an infinite number of photons

Answer Key for Exam A

Section 1. Multiple Choice

- | | |
|---------|---------|
| 1. (b) | 14. (a) |
| 2. (e) | 15. (d) |
| 3. (e) | 16. (e) |
| 4. (c) | 17. (c) |
| 5. (b) | 18. (c) |
| 6. (b) | 19. (d) |
| 7. (d) | 20. (d) |
| 8. (a) | 21. (e) |
| 9. (b) | 22. (b) |
| 10. (d) | 23. (a) |
| 11. (e) | 24. (d) |
| 12. (b) | 25. (a) |
| 13. (c) | 26. (c) |